

Funik

PCBN insert

Substantially improve cutting efficiency and tool life

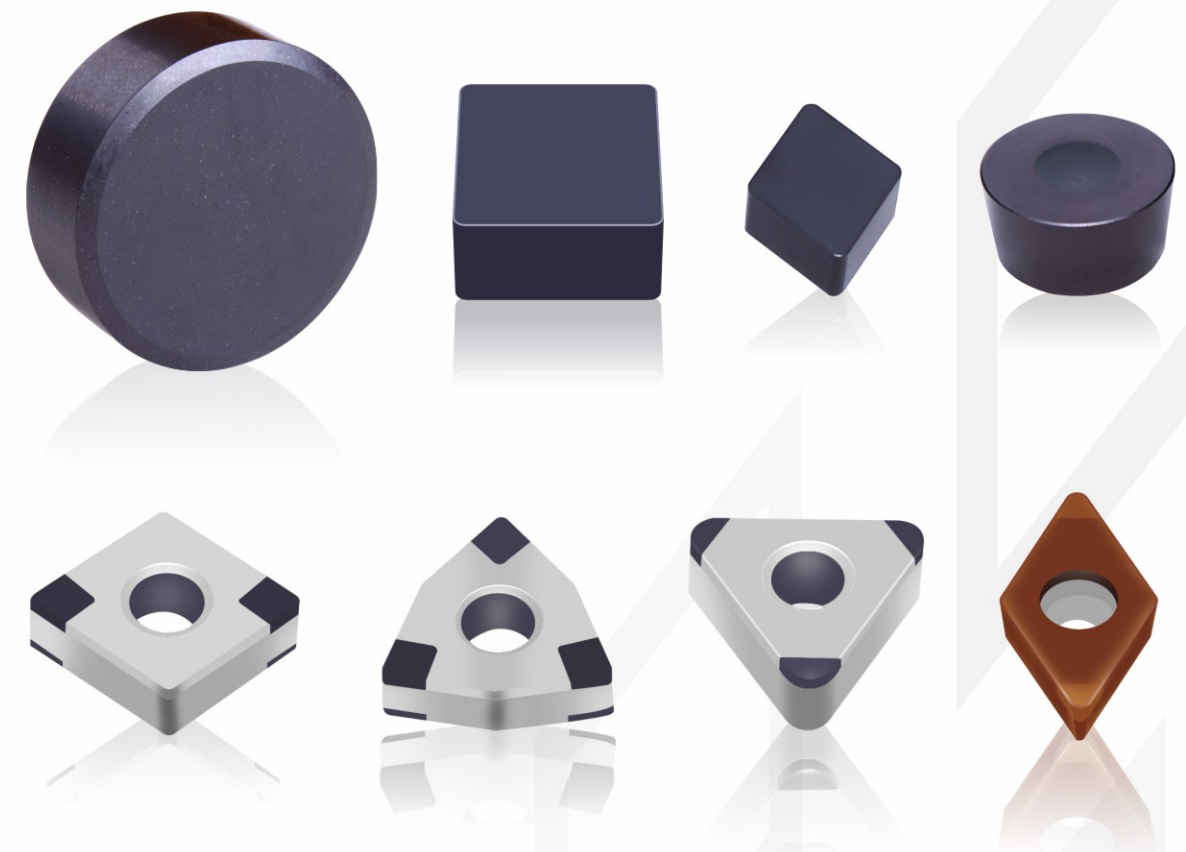

Funik Ultrahard Material Co., Ltd.

Address: No. 16 Dongqing Street, Zhengzhou High-tech Development Zone, China
Tel: +86-371-67987271
Fax: +86-371-67997700
Postcode: 450001
Email: export@funik.com
Website: en.funik.com

Subverting the tradition Enlightening the future

ISO9001/ISO14001/ISO45001 Certified

Advantages of Funik Innovative PCBN insert

Focusing on revolutionary technological innovation on CBN micro-nano materials, composites and cutting tool application, and advanced controlling and manufacturing process, Funik is able to develop and manufacture the most consistent high-quality PCBN solid inserts with high impact resistance, more economical double-layer inserts, super finishing single-layer inserts and inserts with cutting-edge coating techniques. It fully meets the requirements of wear resistance, impact resistance, thermal stability and chemical stability of metal machining.

Our PCBN inserts are widely used in processing pearlitic cast iron, high chromium and nickel alloy cast iron, hardened steel, powder metal, hard alloy and super alloy. In the mechanical machining application of the traditional system, not only it has greatly reduced the comprehensive production cost, but also significantly improved the production capacity and efficiency during the whole production operation, and the equipment investment is greatly decreased at the same time.

● Excellent cost performance

The service life of Funik PCBN insert can be more than 10 times that of carbide insert and reduce the cost of comprehensive cutting tool by 30%-50%. The interval time between the replacements of Funik PCBN insert is long and the insert replacement frequency is less, which can significantly reduce the cost on inserts.

● High machining efficiency

The machining efficiency of Funik PCBN insert is 5-10 times that of the carbide insert, which greatly improves the equipment capacity and reduces the fixed investment of equipment.

● Excellent surface quality

Surface finish and dimensional precision of machining workpiece of Funik PCBN insert can reach the grinding level, and make turning instead of grinding to reduce equipment investment.

● Strong universality

Funik PCBN insert can be used for both dry cutting and wet cutting and one grade normally is suitable for machining a variety of materials.

Grade and Applicable Industry of Funik FBN Impact-resistant Solid Insert

Grade	Machining Model	Applicable Industry	Workpiece Material	Feature
FBN7600	Rough machining / Semi-finishing	<ul style="list-style-type: none"> Roll, slurry pump Brake disc Brake drum Rolling mortar wall Parts of compressor 	<ul style="list-style-type: none"> High nickel-chromium, high hardness alloy cast iron and high speed steel Gray cast iron High manganese steel 	<ul style="list-style-type: none"> Wonderful combination of toughness and wear resistance, and good cutting edge stability Good universality, suitable for high-speed heavy loading rough machining from interrupted to continuous working conditions
FBN9500	Rough machining / Semi-finishing	<ul style="list-style-type: none"> Gear Bearing Mining machinery Coal mine machinery 	<ul style="list-style-type: none"> Hardened steel Surface overlaying material 	<ul style="list-style-type: none"> Balanced impact toughness and good wear resistance Suitable for severe interrupted to continuous machining under various working conditions

Grade and Applicable Industry of Funik FBV Double-layer Composite Insert

Grade	Machining Model	Applicable Industry	Workpiece Material	Feature
FBV7200	Finishing	<ul style="list-style-type: none"> Brake disc Brake drum Parts of compressor 	<ul style="list-style-type: none"> Gray cast iron 	<ul style="list-style-type: none"> Using CBN particles, with high CBN content, excellent wear resistance Continuous to interrupted high-speed finishing to achieve high quality and stable surface roughness
FBV5800	Finishing	<ul style="list-style-type: none"> Gear Bearing Parts of compressor 	<ul style="list-style-type: none"> Hardened steel Gray cast iron 	<ul style="list-style-type: none"> Excellent wear resistance and crater wear resistance Performance is best for continuous to mild interrupted finishing











Grade and Applicable Industry of Funik Innovative FBN or FBV Coating Insert

Grade	Machining Model	Applicable Industry	Workpiece Material	Feature
FBN9500 C06	Semi-finishing / Finishing	<ul style="list-style-type: none"> Gear Bearing Mining machinery Coal mine machinery 	<ul style="list-style-type: none"> Hardened steel Cemented steel Surface overlaying material 	<ul style="list-style-type: none"> CBN material covered with brown PVD coating, more excellent wear resistance The coating bonding strength is high and it can maintain stable machining for a long time, and life is about 50% longer than FBN9500
FBV7200 C07	Finishing	<ul style="list-style-type: none"> Brake disc Brake drum Parts of compressor 	<ul style="list-style-type: none"> Gray cast iron 	<ul style="list-style-type: none"> The coating can achieve stable and excellent roughness in high precision machining The coating bonding strength is high and it can achieve a long machining life, which is about 30%-50% longer than FBV7200
FBV5800 C06	Finishing	<ul style="list-style-type: none"> Gear Bearing Parts of compressor 	<ul style="list-style-type: none"> Hardened steel Gray cast iron 	<ul style="list-style-type: none"> The coating improves the ability of the insert to suppress the crater wear The coating bonding strength is high and it can maintain stable machining for a long time, and life is about 50% longer than FBV5800











Grade and Applicable Industry of Funik FBK Single-layer Composite Super finishing Coating Insert

Grade	Machining Model	Applicable Industry	Workpiece Material	Feature	Cutting speed Vc (m/min)	Cutting fluid
FBK7520 C07	Finishing	<ul style="list-style-type: none"> Brake disc Gear 	<ul style="list-style-type: none"> Gray cast iron 	<ul style="list-style-type: none"> Capable of the machining of various materials From interrupted to continuous high speed finishing The coating bonding strength is strong and it can effectively improve the life of cutting tool 	600-1200	Dry cut or wet cut
			<ul style="list-style-type: none"> Powder metallurgy 		90-200	
FBK9540 C06	Finishing	<ul style="list-style-type: none"> Gear Bearing 	<ul style="list-style-type: none"> Hardened steel 	<ul style="list-style-type: none"> Excellent thermal stability and red hardness result in prominent wear resistance High speed continuous finishing The excellent high temperature and wear resistance of the coating can significantly reduce the wear of the cutting tip 	180-300	Dry cut or wet cut
FBK9550 C06	Finishing	<ul style="list-style-type: none"> Gear Bearing 	<ul style="list-style-type: none"> Bearing steel Cemented steel 	<ul style="list-style-type: none"> The wear resistance and collapse resistance are relatively balanced Medium interrupted and continuous finishing The excellent high temperature and wear resistance of the coating can significantly reduce the wear of the cutting tip 	100-175	Dry cut or wet cut
FBK9560 C06	Finishing	<ul style="list-style-type: none"> Gear Bearing 	<ul style="list-style-type: none"> Cemented steel 	<ul style="list-style-type: none"> Strong collapse resistance and cutting tip handling Heavy interrupted finishing The excellent high temperature and wear resistance of the coating can significantly reduce the wear of the tool nose 	100-200	Dry cut



Funik FBN Impact-resistant Solid Insert

Grade	Insert shape	Insert model	Radius	Chamfer							
				02020	02030	02530	03020	05020	10020	20020	
FBN7600		RNGN0904	00	●							
		RNGN1204	00	●					●		
		RNMN1207	00	●				●			
		RNMN1507	00	●							
		RNMN2007	00					●			
		RNMN2010	00					●		●	
		RCGX0907Y	00	●				●			
		RCGX1207Y	00					●	●		
		RCGX0907V	00	●				●			
		RCGX1207V	00					●	●		
		RCGO1207	00		●						
		SNMN1207	12	●			●				
		SNMN1507	16				●	●			
		SNMN2010	20					●			
		CNMN1207	12	●			●				
16			●		●						
FBN9500		RNGN0904	00	●							
		RNGN1204	00	●							
		RNMN1207	00	●				●			
		RCGX0907Y	00	●				●			
		RCGX1207Y	00		●		●				
		RCGX0907V	00	●				●			
		RCGX1207V	00		●		●				
		RCGO1207	00		●						
		SNMN1207	12	●							
		SNMN1507	16					●			
	CNMN1207	08	●								
		12	●								



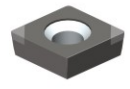
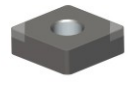
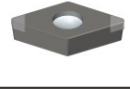
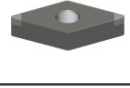

Funik FBV Super Finishing Double-layer Composite Insert

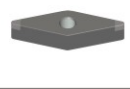
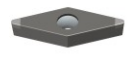
Grade	Insert shape	Insert model	Radius	Chamfer						
				E	01010	01015	01520	02020	02025	02530
FBV7200		CNGA1204	08		●					
		DNGA1504	12					●		
		SNGN0904	08	●	●					
			12		●					
		SCGN0904	08	●	●					
			12	●	●					
		SNGN1204	12		●					
			16			●				
		TNGA1604	08				●			
		WNGA0804	08			●				
12						●				
FBV5800		CNGA1204	08				●	●		
			16					●		
		DNGA1504	08				●			
		TNGA1604	08						●	
		VNGA1604	08	●	●					
		WNGA0804	08				●			
			12				●			

Funik FBK Single-layer Composite Super Finishing Coating Insert

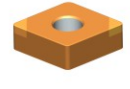
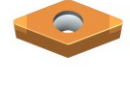
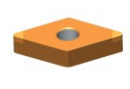
Grade	Insert shape	Insert model	Radius	Chamfer						
				01015	01020	01225	01520	01530	02020	
FBK7520C07		CCGW0602	04		•					
		CCGW09T3	04	•						
		CCGW1204	12				•			
		CNGA1204	08				•			
			16		•					
		DCGW11T3	04			•				
		DNGA1504	08			•				
		TCGW0902	04		•					
			TCGW1102	04		•				
		TCGW1102	08		•					
		TNGA1604	16							•
		VNGA1604	04					•		
		VCGW1604	04			•				

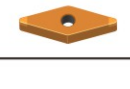
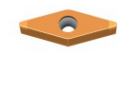
Funik FBK Single-layer Composite Super Finishing Coating Insert

Grade	Insert shape	Insert model	Radius	Chamfer							
				01010	01020	01225	01525	01535	02035	03035	
FBK9540C06 FBK9550C06 FBK9560C06		CCGW0602	04		•						
		CCGW09T3	04		•		•				
			08			•	•				
	CCGW1204	04		•							
		CNGA1204	08			•					
			12			•					
		DCGW0702	04		•						
			DCGW11T3	04			•				
		DCGW11T3	08				•				•
		DNGA1504	04			•				•	
			08			•					
		TCGW0902	04		•						
			TCGW1102	04	•		•				
		TCGW1103	04	•							
	TCGW1103	08				•					
		TNGA1604	08			•		•			
	VNGA1604	08		•			•				
	VBGW1604	04			•						
		08		•	•						
	WNGA0804	08			•		•				

Presentation Rule for Model of Funik Insert

Shape code	Insert	Insert shape	Angle
S		Square	90°
T		Regular triangle	60°
C		Rhombus (Diamond frame)	80°
D			55°
E			75°
M			86°
V			35°
W		Raised triangle	80°
H		Regular hexagon	120°
O		Regular octagon	135°
P		Regular pentagon	108°
L		Rectangle	90°
A		Parallelogram	85°
B			82°
N/K			55°
R		Roundness	-

The number of edges is even number

The number of edges is odd number

Insert with wiper

Code	Height m of cutting tip Tolerance (mm)	Inscribed circle Tolerance (mm)	Thickness S Tolerance (mm)	Code	Height m of cutting tip Tolerance (mm)	Incircle Tolerance (mm)	Thickness S Tolerance (mm)
A	±0.005	±0.025	±0.025	J	±0.005	±0.05- ±0.13	±0.025
F	±0.005	±0.013	±0.025	K	±0.013	±0.05- ±0.13	±0.025
C	±0.013	±0.025	±0.025	L	±0.025	±0.05- ±0.13	±0.025
H	±0.013	±0.013	±0.025	M	±0.08 - ±0.18	±0.05- ±0.13	±0.13
E	±0.025	±0.025	±0.025	N	±0.08 - ±0.18	±0.05- ±0.13	±0.025
G	±0.025	±0.025	±0.13	U	±0.13- ±0.38	±0.08- ±0.25	±0.13

Presentation Rule for Model of Funik Insert

Inscribed circle (mm)	Length of cutting edge						
	C	D	S	T	V	W	R
3.97				06			03
4.76				08			04
5.0							05
5.56				09	09		05
6.0							06
6.35	06	07	06	11	11	04	06
7.94	08	09					07
8.0							08
9.525	09	11	09	16	16	06	09
10.0							10
12.0							12
12.7	12	15	12	22	22	08	12
15.875	16		15	27			15
16.0		19					16
19.05	19		19	33			19
20.0							20
25.0	25	25					25
25.4			25				25
31.75							31
32							32

*Thickness is the height between the bottom of the insert and the top part of the cutting edge.

Code	Thickness of insert (mm)	Code	Thickness of insert (mm)
01	1.59	06	6.35
T1	1.98	07	7.94
02	2.38	08	8.0
T2	2.58	09	9.52
03	3.18	10	10.0
T3	3.97	11	11.11
04	4.76	12	12.0
05	5.56	12	12.70

Code	Corner radius (mm)
00	No radius or circular insert
02	0.2
04	0.4
08	0.8
12	1.2
16	1.6
20	2.0
24	2.4
32	3.2
X	Others

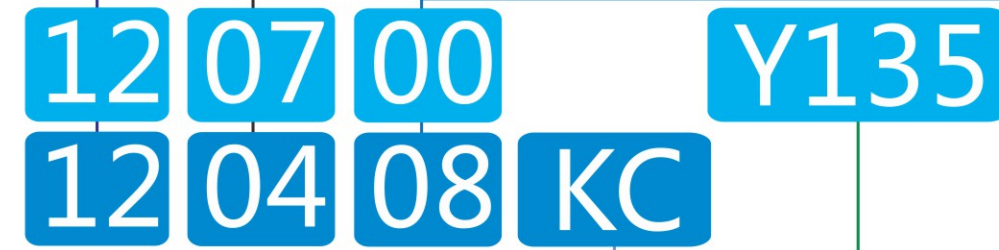

Code	Clearance angle
N	0°
A	3°
B	5°
C	7°
P	11°
D	15°
E	20°
F	25°
G	30°
O	Other clearance angles

Chip breaker and clamping form							
Code	With or without hole and hole shape	Chip breaker	Sketch map	Code	With or without hole and hole shape	Chip breaker	Sketch map
N	Non	Non chip breaker		B	Single side with 70°-90° counter bore	Non chip breaker	
R		Single side with chip breaker		H		Single side with chip breaker	
F		Double sides with chip breaker		C	Double sides with 70°-90° counter bore	Non chip breaker	
A	Non chip breaker		J	Double sides with chip breaker			
M	Round and straight hole	Single side with chip breaker		O	Fastening dimple	Roundness	
G		Double sides with chip breaker		S		Roundness	
W	Single side with 40°-60° counter bore	Non chip breaker		L		Long strip	Roundness
T		Single side with chip breaker					
Q	Double sides with 40°-60° counter bore	Non chip breaker					
U		Double sides with chip breaker					
X	Other forms of fixing and chip breaker shall be illustrated by drawings						

Arbitrary sign

Main cutting edge style
Cutting direction or chip breaker form
It is blank if there is none

Pyramid or cone bottom

Y: Cone bottom

Y means the cone bottom, and 135 means the 135° of cone angle, If the cone angle is 120°, it can be blank.
Example: The model No. of 120° cone bottom insert is RCMX120700Y.
It also can be RCMX120700Y120.
Non-120° cone angle must be marked
Example: The model No. of 135° cone bottom insert is RCMX120700Y135

V: Pyramid bottom

V means the pyramid bottom, and 135 means the 135° of pyramid angle, If the pyramid angle is 120°, it can be blank
Example: The model No. of the 120° pyramid bottom insert is RCMX120700V
It also can be RCMX120700V120
Non-120° pyramid angle must be marked
Example: The model No. of 135° pyramid bottom insert is RCMX120700V135

Note: If there is no V or Y in the model No., for example: RCMX120700, it is shown as the V-shaped base.

Naming Standard of Funik Innovative PCBN Insert Cutting Edge

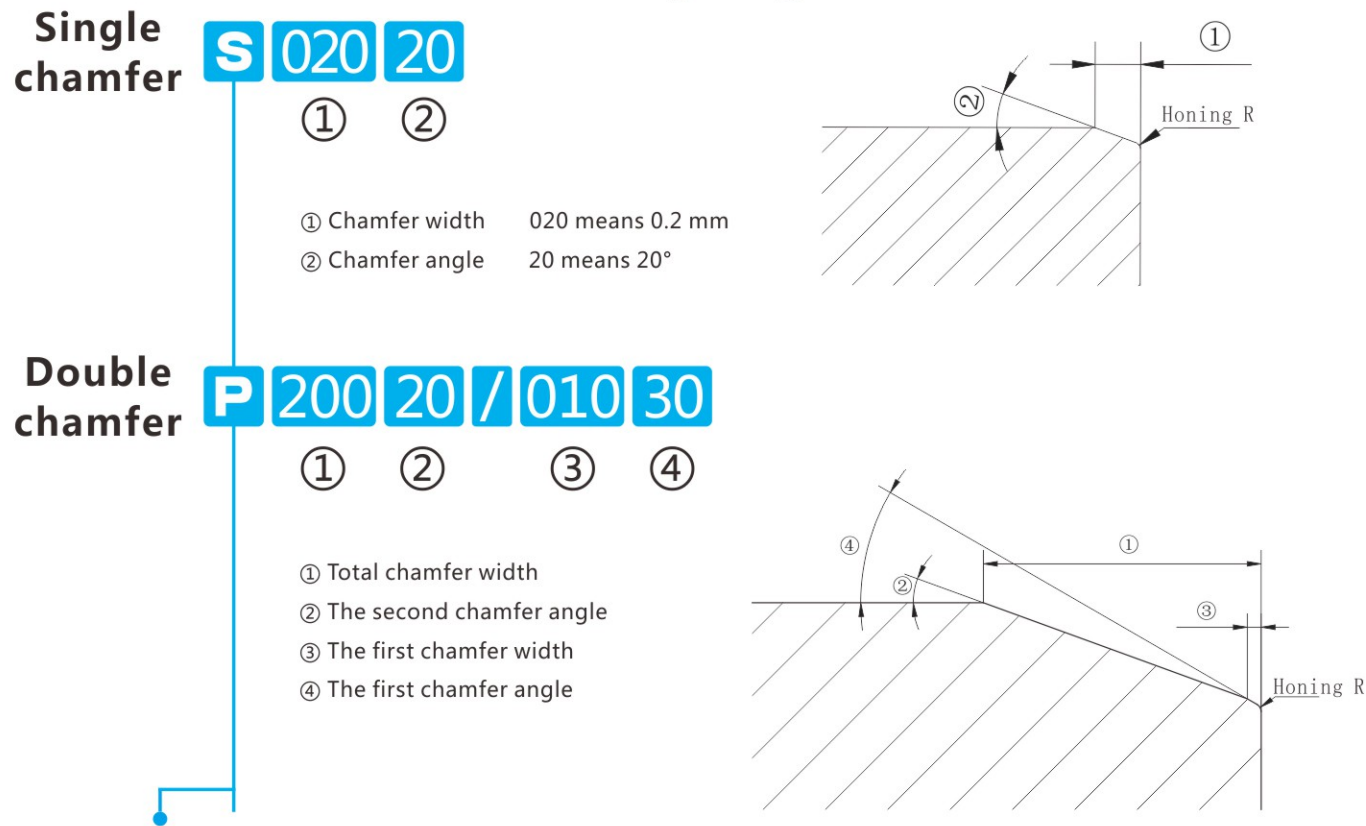

Cutting edge preparation			Main Function
Code	Cutting edge preparation	Drawing	
F	Sharp cutting edge		Sharp cutting edge is helpful to improve the machined surface roughness, and it is difficult to produce vibration marks. But being too sharp will cause slightly worse durability, so it is only applicable in the machining of general cast iron and higher roughness requirements.
E	Honing		Honing can reduce the micro chipping, improve the integrity of cutting edge and prolong life of cutting tool. The heavier the honing, the more intact the Cutting edge preparation, and the better the strength, but the cutting resistance and cutting heat will also be increased. When the system rigidity and machine power are enough or the cutting is interrupted, the heavy Honing can be chosen.
T	Chamfer		Chamfer can improve the impact resistance of cutting edge. Compared with the S cutting edge, it is beneficial to improve the machined surface quality and ensure the stability of dimension.
S	Chamfer + Honing		The strength and comprehensive performance of cutting edge are the best, and the cutting edge is the most widely used in CBN cutting tool. S05020 is more applicable for turning alloy hard cast iron, S02020 is more applicable for gray cast iron, and S01020 is more applicable for hardened steel.
K	Double chamfer		It is recommended in large allowance and interrupted turning to obtain better impact resistance.
P	Double chamfer + Honing		It is recommended in large allowance and interrupted turning to obtain better impact resistance and better strength than K cutting edge.

Example and Instruction for the Order of Funik Innovative PCBN insert

FBN **7600** **RCGX120700Y135** **S05020**

FBV **5800** **WNGA080408** **S01020**

FBK **9540** **CNGA120408KC** **-2** **S** **S02020**

FBN: Solid PCBN insert
 FBV: Superhard double-layer composite brazed solid PCBN insert
 FBK: Single-layer braze composite PCBN insert

Effective number of the insert cutting tips It shall be blank, if there is one cutting tip -2 means there are two effective cutting tips It can be blank for FBN or FBV insert

See P6-7 for the specification and model

Here are the coating and type. It shall be blank, if there is no coating layer.

See P1 for the grade

FBK inserts cutting edge length standard insert (short) N: Length of the standard insert (long) L: Length of the special effective cutting edge Example: L35 means the length of an effective cutting edge is 3.5mm

See P8 for the Cutting edge preparation

Industrial application of Funik innovative PCBN insert

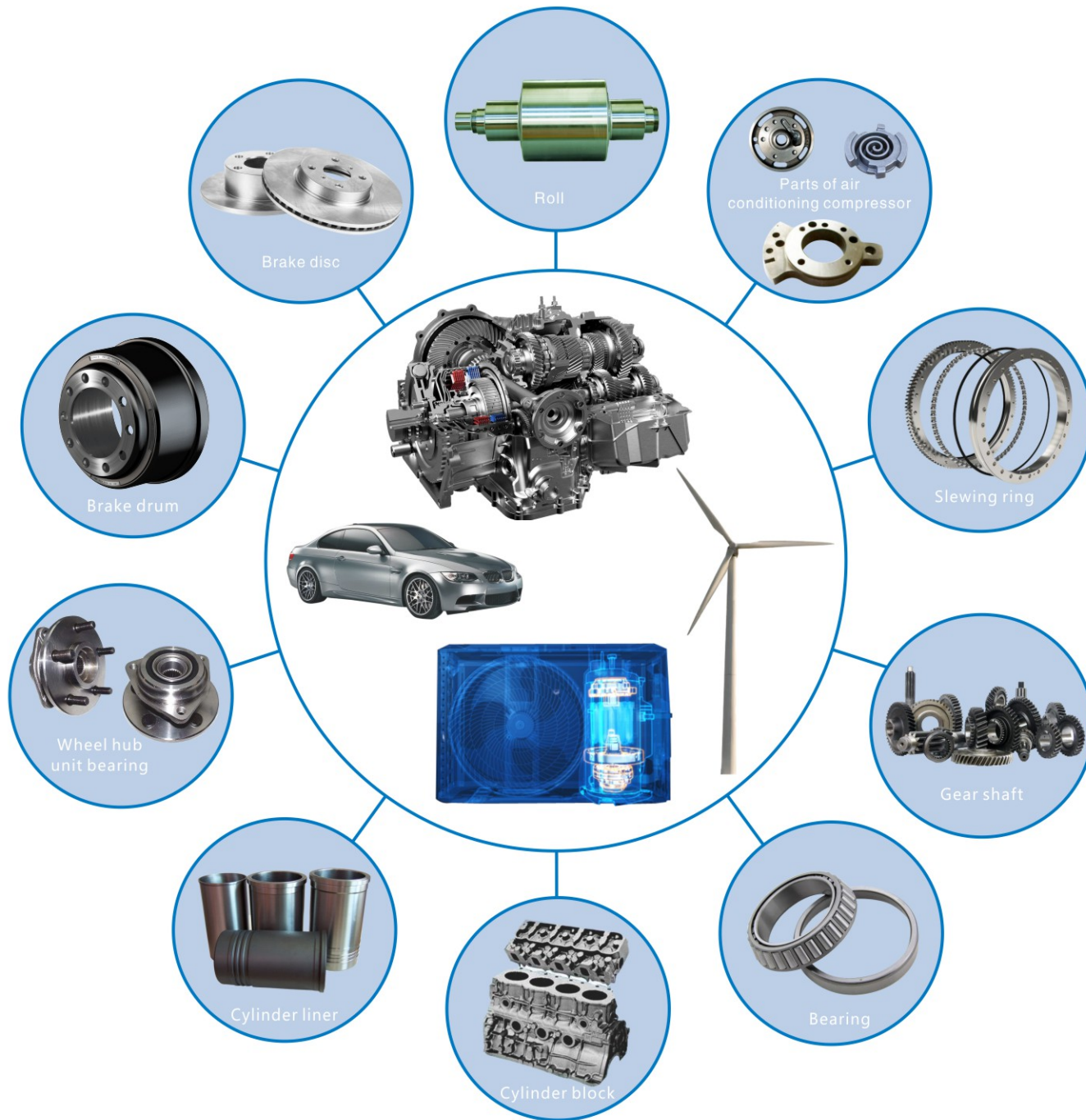

Application case of Funik innovative PCBN insert in auto parts

Industry - Auto parts - Brake disc

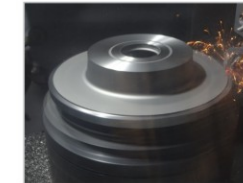

Funik CBN cutting tool:
The life is increased by **400%**
The efficiency is promoted by **29%**

Workpiece name: Brake disc
Workpiece material: HT250
Workpiece hardness: HB190-210
Machining position: Brake surface
Machining type: Continuous, rough machining
Insert grade: FBN7600
Insert specification: SNMN120712
Cutting type: Dry cutting
Cutting parameters: Vc=800m/min ap=2-3mm
f = 0.45mm/r

Cutting tool contrast	Cutting speed Vc(m/min)	Efficiency (s / pcs)	Life(pcs / cutting edge)
Some European and American brands	700	7	200
Funik FBN7600	800	5	1000

Industry - Auto parts - Brake disc

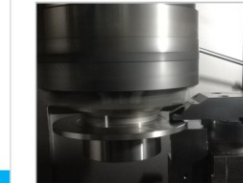

Funik CBN cutting tool:
The life is increased by **300%**
The efficiency is promoted by **30%**

Workpiece name: Brake disc
Workpiece material: HT250
Workpiece hardness: HB190-210
Machining position: Brake surface
Machining type: Continuous, finishing
Insert grade: FBV7200
Insert specification: SCGN090408FC
Cutting type: Dry cutting
Cutting parameters: Vc=600m/min ap=0.25mm
f = 0.3mm/r

Cutting tool contrast	Cutting speed Vc(m/min)	Efficiency (s / pcs)	Life(pcs / cutting edge)
Some domestic CBN	450	30	30
Funik FBV7200	600	20	120

Industry - Auto parts - Brake drum

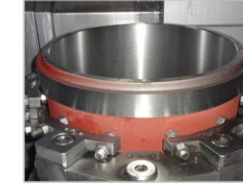

Funik CBN cutting tool:
The life is increased by **300%**
The efficiency is promoted by **43%**

Workpiece name: Brake drum
Workpiece material: HT250
Workpiece hardness: HB190-210
Machining position: Outer circle, inner diameter
Machining type: Continuous, rough machining
Insert grade: FBN7600
Insert specification: CNMN120716
Cutting type: Wet cutting
Cutting parameters: Vc=1130m/min ap=2-3mm
f = 0.5mm/r

Cutting tool contrast	Cutting speed Vc(m/min)	Efficiency (min / pcs)	Life(pcs / cutting edge)
Some domestic CBN	920	3.5	15
Funik FBN7600	1130	2	60

Industry - Auto parts - Belt pulley



Funik CBN cutting tool:
The life is increased by **20%**
The efficiency is promoted by **32%**

Workpiece name: Belt pulley
Workpiece material: Gray cast iron
Workpiece hardness: HB220
Machining position: Outer circle, end face
Machining type: Continuous finishing
Insert grade: FBK7520C07
Insert specification: DNGA150408
Cutting type: Wet cutting
Cutting parameters: Vc=427m/min ap=0.2mm
f = 0.1mm/r

Cutting tool contrast	Cutting speed Vc(m/min)	Efficiency (s / pcs)	Life(pcs / cutting edge)
Some Japanese and Korean CBN	301	19	250
Funik FBK7520 C07	427	13	300

Industry - Auto parts - Cylinder liner



Funik CBN cutting tool:
The life is increased by **600%**
The efficiency is promoted by **13%**

Workpiece name: Cylinder liner
Workpiece material: Alloy cast iron
Workpiece hardness: HB230-260
Machining position: Inner hole
Machining type: Continuous finishing
Insert grade: FBV7200
Insert specification: CCGW09T304
Cutting type: Wet cutting
Cutting parameters: Vc=300m/min ap=0.6mm
f = 0.25mm/r

Cutting tool contrast	Cutting speed Vc(m/min)	Efficiency (s / pcs)	Life(pcs / cutting edge)
Some Japanese and Korean ceramics	250	80	100
Funik FBV7200	300	70	700

Industry - Auto parts - CV joint



Funik CBN cutting tool:
The life is increased by **20%**
The efficiency is promoted by **17%**

Workpiece name: CV joint
Workpiece material: S55C (No. 55 steel)
Workpiece hardness: HRC58-62 (No quenching in the chuck)
Machining position: Outer circle
Machining type: Finishing
Insert grade: FBK9550C06
Insert specification: DNGM150408FV
Cutting type: Dry cutting
Cutting parameters: Vc=120m/min ap=0.2-0.3mm
f = 0.2mm/r

Cutting tool contrast	Cutting speed Vc(m/min)	Efficiency (s / pcs)	Life(pcs / cutting edge)
Some Japanese brand	100	30	250
Funik FBK9550 C06	120	25	300

Industry - Auto parts - Flywheel



Funik CBN cutting tool:
The life is increased by **54%**
The efficiency is promoted by **25%**

Workpiece name: Flywheel
Workpiece material: HT250
Workpiece hardness: HB190
Machining position: Plane and inner diameter
Machining type: Finishing
Insert grade: FBN7600
Insert specification: RCMX090700Y
Cutting type: Dry cutting
Cutting parameters: Vc=247m/min ap=0.5mm
f = 0.2mm/r

Cutting tool contrast	Cutting speed Vc(m/min)	Efficiency (s / pcs)	Life(pcs / cutting edge)
Some domestic brand	178	24	65
Funik FBN7600	247	18	100

Industry - Auto parts - Turbocharger



Funik CBN cutting tool:
The life is increased by **30%**
The efficiency is promoted by **33%**

Workpiece name: Turbocharger
Workpiece material: Alloy cast iron
Workpiece hardness: HRC55-60
Machining position: Inner hole
Machining type: Finishing
Insert grade: FBK7520C07
Insert specification: VCGW160404
Cutting type: Dry cutting
Cutting parameters: Vc=120m/min ap=0.2mm
f = 0.1mm/r

Cutting tool contrast	Cutting speed Vc(m/min)	Efficiency (s / pcs)	Life(pcs / cutting edge)
Some domestic brand	80	75	70
Funik FBK7520 C07	120	50	90

Application case of Funik innovative PCBN insert in roll

Industry - Roll - Strip roll

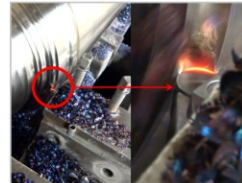

Funik CBN cutting tool:
The life is increased by 100%
The efficiency is promoted by 25%

Workpiece name: Strip roll
Workpiece material: High NiCr
Workpiece hardness: HSD75-85
Machining position: Shoulder, roll body
Machining type: Rough machining
Insert grade: FBN7600
Insert specification: RNMN201000
Cutting type: Dry cutting
Cutting parameters: Vc=40m/min ap=10mm
f = 0.5mm/r

Cutting tool contrast	Cutting speed Vc(m/min)	Efficiency (min / pcs)	Life(pcs / cutting edge)
Some domestic brand	30	200	1
Funik FBN7600	40	150	2

Industry - Roll - H-shaped steel roll

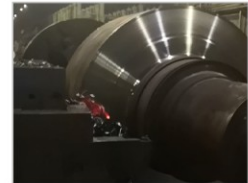

Funik CBN cutting tool:
The life is increased by 100%
The efficiency is promoted by 40%

Workpiece name: H-shaped steel roll
Workpiece material: High carbon semi-steel
Workpiece hardness: HSD55-65
Machining position: Roll body, end face
Machining type: Rough machining
Insert grade: FBN7600
Insert specification: RNMN201000
Cutting type: Dry cutting
Cutting parameters: Vc=94m/min ap=10mm
f = 0.4mm/r

Cutting tool contrast	Cutting speed Vc(m/min)	Efficiency (min / pcs)	Life(pcs / cutting edge)
Some domestic brand	56	85	0.5
Funik FBN7600	94	50	1

Industry - Roll - Screw thread steel roll



Funik CBN cutting tool:
The life is increased by 200%
The efficiency is promoted by 33%

Workpiece name: Screw thread steel roll
Workpiece material: High speed steel
Workpiece hardness: HSD80-85
Machining position: Outer circle of roll body, groove
Machining type: Rough machining
Insert grade: FBN7600
Insert specification: RCMX120700Y
Cutting type: Dry cutting
Cutting parameters: Vc=72m/min ap=2mm f = 0.4mm/r

Cutting tool contrast	Cutting speed Vc(m/min)	Efficiency (min / pcs)	Life(pcs / cutting edge)
Some domestic brand	48	60	1
Funik FBN7600	72	40	3

Industry - Roll - Screw thread steel roll



Funik CBN cutting tool:
The life is increased by 100%
The efficiency is promoted by 33%

Workpiece name: Screw thread steel roll
Workpiece material: High speed steel
Workpiece hardness: HSD80-85
Machining position: Outer circle of roll body, groove
Machining type: Finishing
Insert grade: FBN7600
Insert specification: RCMX090700Y
Cutting type: Dry cutting
Cutting parameters: Vc=103m/min ap=0.3mm
f = 0.2mm/r

Cutting tool contrast	Cutting speed Vc(m/min)	Efficiency (min / pcs)	Life(pcs / cutting edge)
Some domestic brand	68	90	1
Funik FBN7600	103	60	2

Application case of Funik innovative PCBN insert in air conditioning compressor

Industry - Air conditioning compressor - Air cylinder

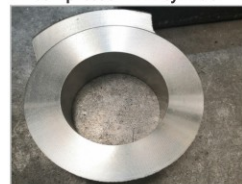

Funik CBN cutting tool:
The life is increased by 25%
The efficiency is promoted by 20%

Workpiece name: Air cylinder
Workpiece material: HT250
Workpiece hardness: HB190-210
Machining position: End face, outer circle
Machining type: Rough machining
Insert grade: FBN7600
Insert specification: SNGN120712
Cutting type: Dry cutting
Cutting parameters: Vc=760m/min ap=1mm
f = 0.4mm/r

Cutting tool contrast	Rotational speed n(r/min)	Efficiency (s / pcs)	Life(pcs / cutting edge)
Some domestic brand	1800	37	1200
Funik FBN7600	2200	30	1500

Industry - Air conditioning compressor - Upper bearing



Funik CBN cutting tool:
The life is increased by 30%
The efficiency is promoted by 20%

Workpiece name: Upper bearing
Workpiece material: HT250
Workpiece hardness: HB190-210
Machining position: Outer circle of shank, end face
Machining type: Finishing
Insert grade: FBV5800
Insert specification: DNGA150408
Cutting type: Dry cutting
Cutting parameters: Vc=450m/min ap=0.3-0.5mm
f = 0.3mm/r

Cutting tool contrast	Rotational speed n(r/min)	Efficiency (s / pcs)	Life(pcs / cutting edge)
Some domestic brand	1800	50	1000
Funik FBV5800	2300	39	1300

Industry - Air conditioning compressor - Lower bearing



Funik CBN cutting tool:
The life is increased by 20%
The efficiency is promoted by 23%

Workpiece name: Lower bearing
Workpiece material: HT250
Workpiece hardness: HB190-210
Machining position: Outer circle, end face
Machining type: Rough machining
Insert grade: FBV5800
Insert specification: WNGA080412
Cutting type: Dry cutting
Cutting parameters: Vc=510m/min ap=0.8-1mm
f = 0.4mm/r

Cutting tool contrast	Rotational speed n(r/min)	Efficiency (s / pcs)	Life(pcs / cutting edge)
Some domestic brand	1800	26	1900
Funik FBV5800	2300	20	2300

Industry - Air conditioning compressor - Flange



Funik CBN cutting tool:
The life is increased by 400%
The efficiency is promoted by 43%

Workpiece name: Flange
Workpiece material: Gray cast iron
Workpiece hardness: HB220
Machining position: Outer circle, end face
Machining type: Continuous finishing
Insert grade: FBV5800
Insert specification: WNGA080408
Cutting type: Dry cutting
Cutting parameters: Vc=534m/min ap=0.4mm
f = 0.26mm/r

Cutting tool contrast	Rotational speed n(r/min)	Efficiency (s / pcs)	Life(pcs / cutting edge)
Some domestic brand	1850	40	80
Funik FBV5800	2200	23	400

Application case of Funik innovative PCBN insert in gear

Industry - Auto parts - Driven gear



Funik CBN cutting tool:
The life is increased by 370%
The efficiency is promoted by 8%

Workpiece name: Driven gear
Workpiece material: 20CrMnTiH
Workpiece hardness: HRC58-62
Machining position: End face, outer circle
Machining type: Continuous, finishing
Insert grade: FBK9560 C06
Insert specification: CNGA120408
Cutting type: Dry cutting
Cutting parameters: Vc=140m/min ap=0.07mm
f = 0.08mm/r

Cutting tool contrast	Cutting speed Vc(m/min)	Efficiency (s / pcs)	Life(pcs / cutting edge)
Some European and American CBN	130	12	150
Funik FBK9560 C06	140	11	1000

Industry - Auto parts - Gear



Funik CBN cutting tool:
The life is increased by 11%
The efficiency is promoted by 20%

Workpiece name: Gear
Workpiece material: 20CrMnTi
Workpiece hardness: HRC58-65
Machining position: Spherical end face
Machining type: Continuous, finishing
Insert grade: FBK9540 C06
Insert specification: TNGA160408
Cutting type: Dry cutting
Cutting parameters: Vc=200m/min ap=0.15mm
f = 0.08mm/r

Cutting tool contrast	Cutting speed Vc(m/min)	Efficiency (s / pcs)	Life(pcs / cutting edge)
Some Japanese CBN	190	5	450
Funik FBK9540 C06	200	4	500

Industry - Auto parts - Rear axle gear



Funik CBN cutting tool:
The life is increased by 25%
The efficiency is promoted by 20%

Workpiece name: Rear axle gear
Workpiece material: 20CrMnTiH
Workpiece hardness: HRC58-62
Machining position: Outer circle + end face
Machining type: Finishing
Insert grade: FBV5800 C06
Insert specification: CNGA120412
Cutting type: Dry cutting
Cutting parameters: Vc=160m/min ap=0.15mm
f = 0.12mm/r

Cutting tool contrast	Cutting speed Vc(m/min)	Efficiency (min / pcs)	Life(pcs / cutting edge)
Some domestic brand	140	1.5	120
Funik FBV5800 C06	160	1.2	150

Industry - Auto parts - Gear ring



Funik CBN cutting tool:
The life is increased by 35%
The efficiency is promoted by 13%

Workpiece name: Gear ring
Workpiece material: SCM420H
Workpiece hardness: HRC45-48
Machining position: Inner end face
Machining type: Finishing
Insert grade: FBK9560 C06
Insert specification: CNGA120412
Cutting type: Dry cutting
Cutting parameters: Vc=140m/min ap=0.13mm
f = 0.12mm/r

Cutting tool contrast	Cutting speed Vc(m/min)	Efficiency (min / pcs)	Life(pcs / cutting edge)
Some domestic brand	120	40秒	80
Funik FBK9560 C06	140	35秒	100

Application case of Funik innovative PCBN insert in gear shaft

Industry - Auto parts - Driven belt pulley shaft



Funik CBN cutting tool:
The life is increased by 50%
The efficiency is promoted by 5%

Workpiece name: Driven belt pulley shaft
Workpiece material: 20CrMnTiH
Workpiece hardness: HRC58-62
Machining position: Outer circle
Machining type: Semi-finishing
Insert grade: FBK9560 C06
Insert specification: CNGA120412
Cutting type: Dry cutting
Cutting parameters: Vc=140m/min ap=0.15mm
f = 0.25mm/r

Cutting tool contrast	Cutting speed Vc(m/min)	Efficiency (min / pcs)	Life(pcs / cutting edge)
Some domestic brand	100	2	80
Funik FBK9560 C06	140	1.9	120

Industry - Auto parts - Gear shaft



Funik CBN cutting tool:
The life is increased by 11%
The efficiency is promoted by 10%

Workpiece name: Intermediate shaft
Workpiece material: 20CrMnTiH
Workpiece hardness: HRC58-62
Machining position: Cylindrical surface at both ends
Machining type: Continuous, finishing
Insert grade: FBK9540 C06
Insert specification: DNGA150408
Cutting type: Dry cutting
Cutting parameters: Vc=180m/min ap=0.25mm
f = 0.08mm/r

Cutting tool contrast	Cutting speed Vc(m/min)	Efficiency (min / pcs)	Life(pcs / cutting edge)
Some Japanese CBN	150	10	120
Funik FBK9540 C06	180	9	600

Industry - Auto parts - Transmission shaft



Funik CBN cutting tool:
The life is increased by 200%
The efficiency is promoted by 14%

Workpiece name: Transmission shaft
Workpiece material: 20CrMo
Workpiece hardness: HRC58-65
Machining position: Cylindrical surface at both ends
Machining type: Light intermittent, finishing
Insert grade: FBK9560 C06
Insert specification: VNGA160408
Cutting type: Wet cutting
Cutting parameters: Vc=180m/min ap=0.1mm
f = 0.15mm/r

Cutting tool contrast	Cutting speed Vc(m/min)	Efficiency (min / pcs)	Life(pcs / cutting edge)
Japanese and Korean CBN	132	7	100
Funik FBK9560 C06	132	6	300

Industry - Auto parts - Wheel hub bearing



Funik CBN cutting tool:
The life is increased by 22%
The efficiency is promoted by 50%

Workpiece name: Wheel hub bearing
Workpiece material: 65Mn
Workpiece hardness: HRC58-63
Machining position: Raceway
Machining type: Continuous, finishing
Insert grade: FBV5800 C06
Insert specification: VNGA160408
Cutting type: Dry cutting
Cutting parameters: Vc=185m/min ap=0.15mm
f = 0.1mm/r

Cutting tool contrast	Cutting speed Vc(m/min)	Efficiency (min / pcs)	Life(pcs / cutting edge)
Some domestic CBN	120	1.5	90
Funik FBV5800 C06	185	1	110

Application case of Funik innovative PCBN insert in other industries

Industry - Wind power - Slewing ring



Funik CBN cutting tool:
The life is increased by 100%
The efficiency is promoted by 15%

Workpiece name: Slewing ring
Workpiece material: 42CrMo
Workpiece hardness: HRC47-55
Machining position: Raceway
Machining type: Intermittent, finishing
Insert grade: FBN9500
Insert specification: RCMX090700
Cutting type: Dry cutting
Cutting parameters: Vc=90m/min ap=0.3mm
f = 0.3mm/r

Cutting tool contrast	Cutting speed Vc(m/min)	Efficiency (min / pcs)	Life(pcs / cutting edge)
Some European and American alloy	70	60	1
Funik FBN9500	90	50	4

Industry - Wind power - Large gear

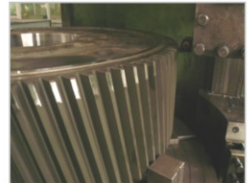

Funik CBN cutting tool:
The life is increased by 700%
The efficiency is promoted by 90%

Workpiece name: Gear
Workpiece material: 42CrMo
Workpiece hardness: HRC45-55
Machining position: Gear tip circle
Machining type: Heavy intermittent, rough machining
Insert grade: FBN9500
Insert specification: SNMN150716
Cutting type: Dry cutting
Cutting parameters: Vc=97m/min ap=4mm
f = 0.7mm/r

Cutting tool contrast	Cutting speed Vc(m/min)	Efficiency (hour / pcs)	Life(pcs / cutting edge)
Some European and American alloy	20	20	0.25
Funik FBN9500	97	2	2

Industry - Engineering machinery - Rolling mortar wall



Funik CBN cutting tool:
The life is increased by 200%
The efficiency is promoted by 14%

Workpiece name: Rolling mortar wall
Workpiece material: High manganese steel
Workpiece hardness: HB240
Machining position: Inner conical surface
Machining type: Continuous, rough machining
Insert grade: FBN7600
Insert specification: SNMN150716
Cutting type: Dry cutting
Cutting parameters: Vc=60m/min ap=6mm
f = 0.4mm/r

Cutting tool contrast	Cutting speed Vc(m/min)	Efficiency (min / pcs)	Life(pcs / cutting edge)
Some European and American CBN	60	70	1
Funik FBN7600	75	60	3

Industry - Automobile - Engine cylinder block



Funik CBN cutting tool:
The life is increased by 460%
The efficiency is promoted by 86%

Workpiece name: Engine cylinder block
Workpiece material: HT250
Workpiece hardness: HB190-210
Machining position: Top face of cylinder block
Machining type: Intermittent, finishing
Insert grade: FBN5800
Insert specification: SNEN090412
Cutting type: Dry cutting
Cutting parameters: Vc=470m/min ap=0.5mm
f = 2000mm/min

Cutting tool contrast	Cutting speed Vc(m/min)	Efficiency (s / pcs)	Life(pcs / cutting edge)
Some European and American alloy	180	84	90
Funik FBN5800	470	12	500

Industry - Mining machinery - Piston rod



Funik CBN cutting tool:
The life is increased by 700%
The efficiency is promoted by 60%

Workpiece name: Piston rod
Workpiece material: 20Cr2Ni4A
Workpiece hardness: HRC58-60
Machining position: Outer circle
Machining type: Continuous, finishing
Insert grade: FBN9500
Insert specification: RNGN090400
Cutting type: Dry cutting
Cutting parameters: Vc=120m/min ap=0.4-0.5mm
f = 0.25mm/r

Cutting tool contrast	Cutting speed Vc(m/min)	Efficiency (min / pcs)	Life(pcs / cutting edge)
Some European and American alloy	48	75	0.5
Funik FBN9500	120	30	4

Industry - Powder metallurgy - Planet carrier



Funik CBN cutting tool:
The life is increased by 200%
The fineness is increased

Workpiece name: Planet carrier
Workpiece material: Powder metallurgy
Workpiece hardness: HB190-210
Machining position: Inner hole
Machining type: Finishing
Insert grade: FBK7520 C07
Insert specification: VCGW160404
Cutting type: Dry cutting
Cutting parameters: Vc=200m/min ap=0.2mm
f = 0.15mm/r

Cutting tool contrast	Cutting speed Vc(m/min)	Efficiency (s / pcs)	Life(pcs / cutting edge)
Some domestic brand	200	30	100
Funik FBK7520 C07	200	30	300

Industry - Automobile - Combined gear



Funik CBN cutting tool:
The life is increased by 400%
The efficiency is promoted by 25%

Workpiece name: Combined gear of gearbox
Workpiece material: 16MnCr5
Workpiece hardness: HRC58-62
Machining position: Inner hole, end face
Machining type: Continuous, finishing
Insert grade: FBK9550 C06
Insert specification: VBGW160404
Cutting type: Dry cutting
Cutting parameters: Vc=160m/min ap=0.1mm
f = 0.01mm/r

Cutting tool contrast	Cutting speed Vc(m/min)	Efficiency (s / pcs)	Life(pcs / cutting edge)
Some Japanese and Korean CBN	140	4	50
Funik FBK9550 C06	160	3	250

Industry - Engineering machinery - Slurry pump



Funik CBN cutting tool:
The life is increased by 100%
The efficiency is promoted by 40%

Workpiece name: Impeller
Workpiece material: Wear resistant white cast iron
Workpiece hardness: HRC50
Machining position: Chamfer
Machining type: Heavy intermittent, rough machining
Insert grade: FBN7600
Insert specification: SNGN120712
Cutting type: Dry cutting
Cutting parameters: Vc=55m/min ap=2-3mm
f = 0.3mm/r

Cutting tool contrast	Cutting speed Vc(m/min)	Efficiency (min / pcs)	Life(pcs / cutting edge)
Some domestic CBN	40	15	1
Funik FBN7600	55	9	2

Common cutting parameters for Funik innovative PCBN insert

Common cutting parameters for Funik PCBN turning insert						
Workpiece	Common material	Hardness	Cutting speed Vc (m/min)	Cutting depth ap (mm)	Feed rate (mm/rev)	Recommended structural form
Gear	20CrMnTi	58-65HRC	100-320	0.1-0.5	0.05-0.2	FBK
Bearing	GCr15	55-65HRC	100-220	0.1-0.5	0.05-0.2	FBK\FBV\FBN
Large gear	40CrMo	310-360HB	40-120	0.5-5.0	0.2-1.0	FBN
	18CrNiMo	58-62HRC	60-120	0.3-1	0.1-0.3	FBN
Slewing ring	42CrMo	55-62HRC	80-220	0.2-2.0	0.1-0.5	FBN
Brake disc			500-1200	0.2-0.5	0.1-0.4	FBN\FBV
			400-1200	0.5-3	0.1-0.4	FBN\FBV
Brake drum	HT250	220-260HB	350-1200	0.2-0.5	0.1-0.4	FBN\FBV
			280-1200	0.5-3	0.1-0.4	FBN\FBV
Compressor bearing			500-1200	0.3-2.5	0.2-0.4	FBN\FBV
Cylinder liner	Boron copper cast iron	180-260HB	500-800	0.1-0.3	0.1-0.2	FBN\FBV\FBK
		180-260HB	150-500	0.3-1.0	0.1-0.3	FBN\FBV\FBK
Roll	High nickel-chromium	78HSD	30-50	1.0-8.0	0.5-1.5	FBN
	High ferrochrome	75HSD	30-45	1.0-10.0		FBN
	High chromium steel	75HSD	20-60	1.0-10.0		FBN
	High speed steel	88HSD	30-60	0.3-3.0		FBN
	High carbon semi-steel	70HSD	45-80	1.0-10.0		FBN
	Chilled cast iron	67HSD	40-60	1.0-10.0		FBN
Slurry pump	Wear resistant white cast iron	50-60HRC	50-100	0.5-4	0.2-0.5	FBN
Rolling mortar wall	High manganese steel	300-500HB	80-200	0.5-8	0.2-0.5	FBN

Common cutting parameters for Funik PCBN milling insert						
Material	Hardness of workpiece	Cutting edge angle Kr	Cutting speed Vc (m/min)	Cutting depth ap (mm)	Feed rate (mm/rev)	Cutting fluid
Gray cast iron	200HB	75°	500-2000	0.50-5.0	0.1-0.2	Dry cut
Gray cast iron	55HRC	75°	150-300	0.5-2.0	0.05-0.2	Dry cut
Hardened steel	60HRC	75°	80-200	0.2-0.5	0.05-0.1	Dry cut

Description: The rigidity and power of machine tool, size and thickness of insert, the material, hardness and shape of workpiece, machining allowance, insert durability and other factors need to be comprehensively considered to make appropriate adjustments in the selection of specific cutting parameters.

Factors that may affect the insert life when PCBN insert is used in machining gray cast iron

- Casting blank should be properly done through aging treatment, and the general natural aging time should be more than 10 days.
- The ferrite content in casting blank should be equal to or less than 10%.
- The sulfur content should be equal to or more than 0.05%.

Failure to meet the above factors may result in a significant decrease in insert life

Precautions for the Use of Funik Innovative PCBN Insert

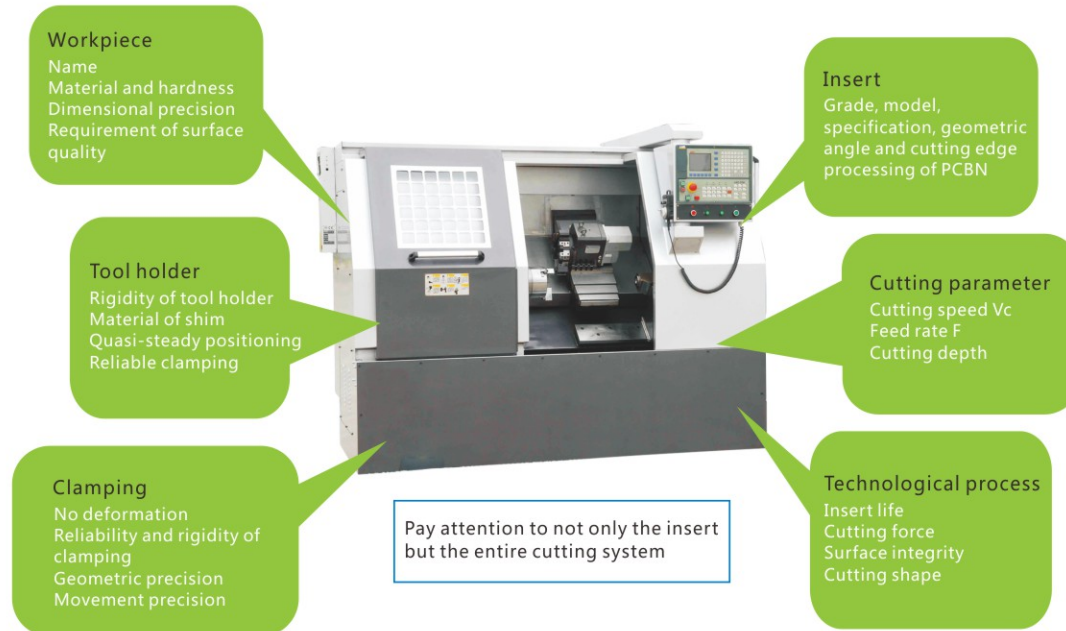

Calculation formula of common cutting parameter

Turning

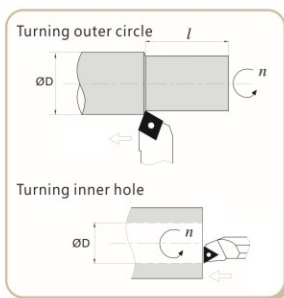

$$V_c = \frac{\pi * D * n}{1000} \text{ (m/min)}$$

$$f = \frac{V_f}{n} \text{ (mm/rev)}$$

In formula: V_c : cutting speed (m/min)
 n : Spindle speed (rev/min)
 D : workpiece diameter (mm)
 V_f : feed speed (mm/min)
 f : feed rate of every rotation (mm/rev)

Milling

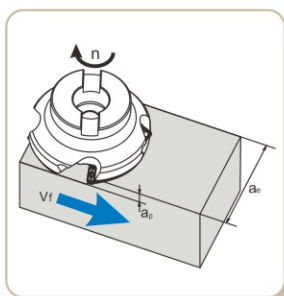

$$V_c = \frac{\pi * D_c * n}{1000} \text{ (m/min)}$$

$$f_z = \frac{V_f}{n * Z} \text{ (mm/z)}$$

In formula: V_c : cutting speed (m/min)
 n : Spindle speed (rev/min)
 D_c : Nominal diameter of milling cutter (mm)
 V_f : feed speed (mm/min)
 Z : Tooth number of insert
 f_z : feed rate of every tooth (mm/rev)

Notes for insert installation

- Thoroughly clean the insert and insert slot
- Check the completeness and wear of the shim
- Check whether the fastening of the shim is reliable
- Check whether the seal face of pressing plate is flat
- Ensure the insert and the positioning slot are closely fit
- Regularly replace the shim, pressing plate and all locking screws
- Avoid using the tool body with worn insert slot
- Keep the minimum overhanging of the tool holder
- Do not stop suddenly before the cutting tip dose not run out in the machining

Company honor

- 1988 Synthesis of Funik's first high-grade cubic boron nitride abrasive
- 1991 Amber cubic boron nitride has been successfully developed
- 1997 High strength black cubic boron nitride has been successfully developed
- 1998 Won the title of "High-tech Enterprise" of Henan Science and Technology Commission
- 2002 National standard formulation unit of Super Abrasive, Cubic Boron Nitride
- 2003 Introduced high wear-resistant and impact-resistant polycrystalline cubic boron nitride inserts
- 2003 Undertook the "National Torch Plan" project of the Ministry of Science and Technology of the People's Republic of China
- 2005 Funik brand won the title of "Famous Brand Products of Henan Province"
- 2006 Won the "50 High-Tech and High-growth Enterprises" named by Henan Provincial Government
- 2006 The first one in the industry was certified by the "three-standard" management system of ISO9001, ISO14001, OHSAS18001
- 2007 Won the title of "Top Ten Enterprises with Comprehensive Economic Benefits in 2006" by China Machine Tool Industry Association
- 2008 Super wear-resistant high-speed finishing polycrystalline cubic boron nitride inserts were successfully put on the market
- 2009 Undertook and implemented the high-tech industrialization project of high-grade cubic boron nitride and high-speed cutting superhard cutting tools of the National Development and Reform Commission
- 2009 Won the title of "Henan Innovative Enterprise" in Henan Province
- 2010 Super brazed cubic boron nitride cutting tools was successfully put on the market
- 2011 Establishment of academician workstation of cubic boron nitride and its products
- 2012 Ultra-precision cubic boron nitride polycrystalline cutting tools was successfully put on the market
- 2014 Won the title of "Innovative Enterprise" of China Materials Research Society
- 2014 The company's shares are listed on the New Three Board, and the securities are referred to as "Funik". The stock code is 831378
- 2015 Won the national standard-setting unit of Polycrystalline Cubic Boron Nitride for Metal Processing
- 2015 Won the title of "Demonstration Enterprise of Technological Innovation in Henan Province in 2015"
- 2015 Won the title of "Top Ten Innovative Enterprises of Henan Economy (2015)"
- 2016 Won the title of "Intellectual Property Advantage Enterprise in Henan Province"
- 2016 Won the title of "Top Ten Product Quality" of cubic boron nitride awarded by China Machine Tool Industry Association
- 2016 Won the title of "Best Service Brand" of the third China Metal Cutting Tool
- 2017 Won the "Excellence Award of China Patent Award"
- 2017 Won the "First Prize for Scientific and Technological Progress in Henan Province"
- 2017 Won the "Top Ten Brands Made in Henan Province in 2017"
- 2018 Obtained the first batch of demonstration items of robot "Ten Hundred Thousand" demonstration application multiplication project in Henan Province in 2018
- 2018 Won the "First Prize for Scientific and Technological Progress in Henan Province"
- 2018 Funik innovative PCD cutting tool was sold more than 200,000 pieces in 3C electronics industry
- 2018 The ϕ 63 large diameter PCD blank was successfully put on the market
- 2018 Won the title of "Henan Intelligent Factory"
- 2019 Won the title of the first batch of special new "Little Giant" enterprises of the Ministry of Industry and Information Technology of the People's Republic of China
- 2019 Won the "Henan Science and Technology Progress Award"
- 2019 Won the "National Intellectual Property Advantage Enterprise"
- 2020 Passed the evaluation of the "Management System for Integration of Informatization and Industrialization"
- 2020 Won the recognition of Henan Research Center of Cubic Boron Nitride Micro-nano Materials and Applied Engineering Technology
- 2020 Funik has accumulated more than 340 national patents